



 **Accessory mounting**  
DXR 250, 270, 275, 300, 305, 310, 315  
**Heat & Cooling function**





# HUSQVARNA

## Heat & Cooling function

**DXR 250, 270, 275,  
300, 305, 310, 315**

## CONTENTS

Page

<b>1. Introduction</b>	<b>1</b>
Accessory spare parts	1
<b>2. Functional overview</b>	<b>3</b>
I. Cooling kit, machine	3
II. Heat protective kit, machine	3
III. Heat protective kit, hammer	3
Specifications	4
<b>3. Hose from external air supply to Y-split</b>	<b>5</b>
Part of kit I and II	5
<b>4. I. Cooling kit, machine</b>	<b>7</b>
<b>5. II. Heat protective kit, machine</b>	<b>11</b>
Air hose to boom bulkhead	11
Heat resistant stick cylinder hoses	12
Heat resistant ground contact surfaces	12
<b>6. III. Heat protective kit, hammer</b>	<b>13</b>
Heat protective extra long chisel tool	13
<b>7. Appendix: Cooling kit, machine</b>	<b>15</b>
A: Counter-weight modifications	16
B: Rear cover modifications	18



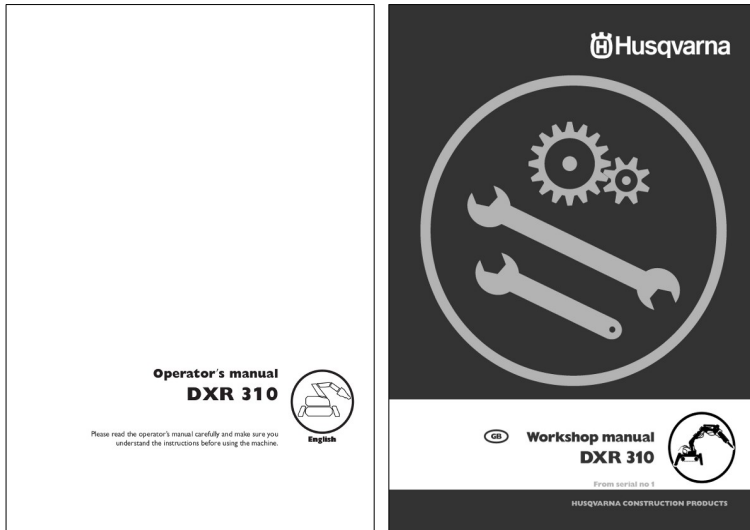

## Accessory Manual

This Accessory Manual covers recommended procedures in mounting the DXR 250–315 accessory heat&cooling kit.

In case of doubt on basic handling of the DXR machine concerned, please refer to the DXR 250–315 Workshop manuals and Operator's manuals.

### OUTLINE

The manual describes mounting in a logical order.

Each chapter begins with suggested preparations before the service items concerned.

### LAYOUT - PICTURES AND TEXT

The pictures are mostly enough to guide the mechanic through the mounting procedures. The text on the right hand column has further references and explanations for the assembling and mounting procedures.

### CONTENTS

The manual is divided into numbered chapters with headings in bold at the top of each page.

## Accessory spare parts

### KIT WITH HEAT & COOLING FUNCTION DXR250—315

All accessory spare parts are part of the latest machine's IPL, available from the EPC (Electronic Parts Catalogue).

All components of the IPLs are illustrated in exploded views, where each component's position, spare part number and appearance can be easily identified. The EPC is available from the Husqvarna Customer Portal.



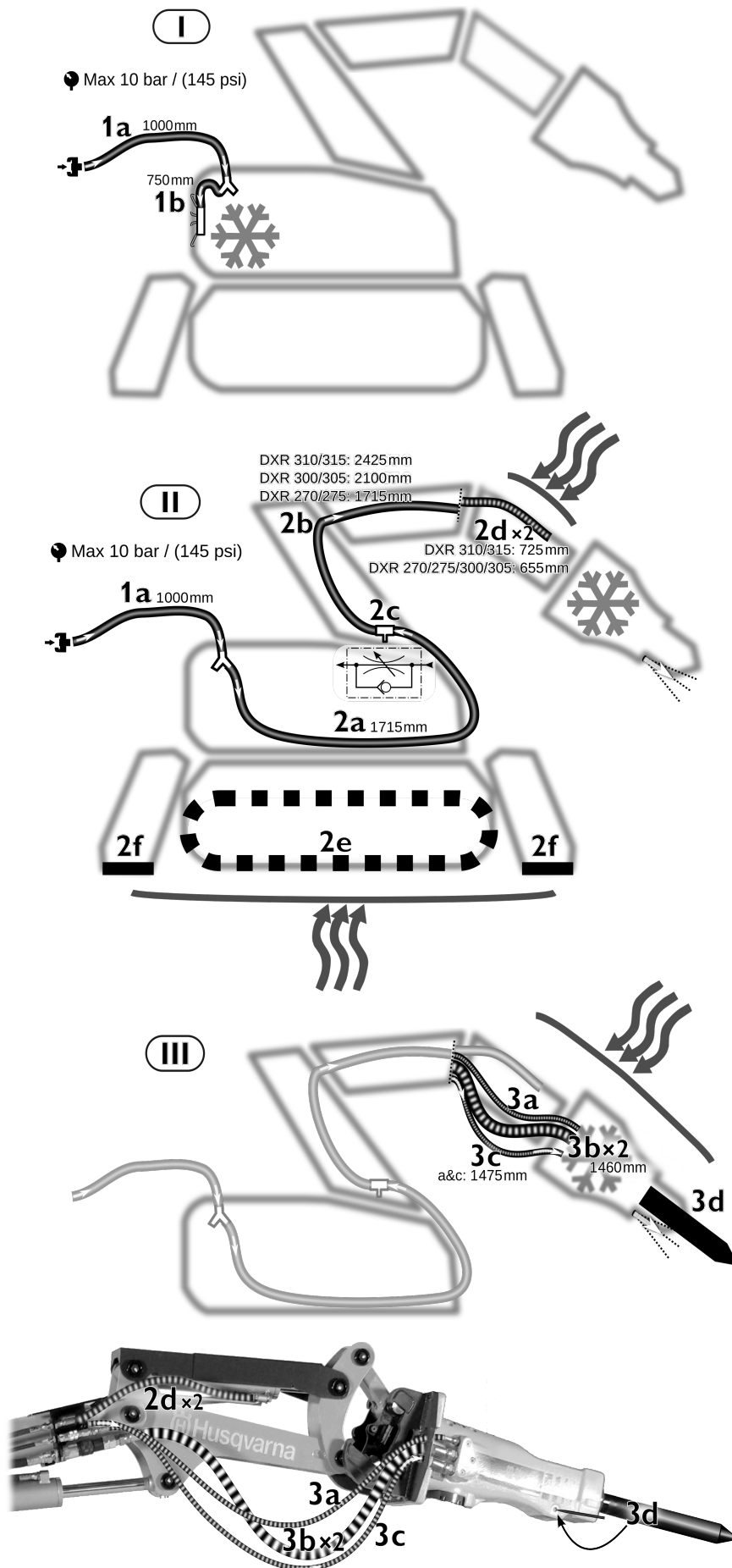

## COOLING & HEAT PROTECTION

These three kits allow for extended use of the DXR demolition robots in various warm environments:

### I. Cooling kit, machine

- 1a** Cooled air from external compressor, by air hose through cable swivel into a Y cable split.
- 1b** Air hose from Y-split to air nozzle frame for machine hydraulic cooler.

DXR	art. No.
<b>270/275</b>	586 70 27 - 01
<b>250/300/305/310/315</b>	586 70 25 - 01

### II. Heat protective kit, machine

- 1a** Same as in 1a above
- 2a** Air hose from Y-split, through machine turret, to boom base.
- 2b** Air hose from boom base to hose bulkhead.
- 2c** One-way flow control valve with reduction screw, connecting hose 2a with 2b.  
**Only reduce this air flow:**
  - if air flow from hammer exit causes too much airborne dust
  - if air supply to machine cooler needs higher priority
- 2d** Hydraulic hose (x2) for stick cylinder with heat protective silicone cover. Replaces existing hoses.
- 2e** Steel tracks (x2) to replace heat sensitive rubber tracks.
- 2f** Steel pads (x4) to replace heat sensitive rubber pads.

DXR	art. No.
<b>270/275</b>	582 71 57 - 01
<b>300/305</b>	582 71 55 - 01
<b>310/315</b>	582 71 54 - 01

### III. Heat protective kit, hammer

To upgrade existing parts:

- 3a** Grease hose for tool with heat protective silicone cover (same as 3c).
- 3b** Hydraulic hoses for tool (x2) with heat protective silicone cover.
- 3c** Air hose with heat protective silicone cover, from bulkhead with quick coupling to tool.
- 3d** Extra long chisel tool for increased distance from radiation source, with lock pin.

Hammer	art. No.
<b>SB202</b>	586 70 26 - 02
<b>SB302</b>	586 70 28 - 02

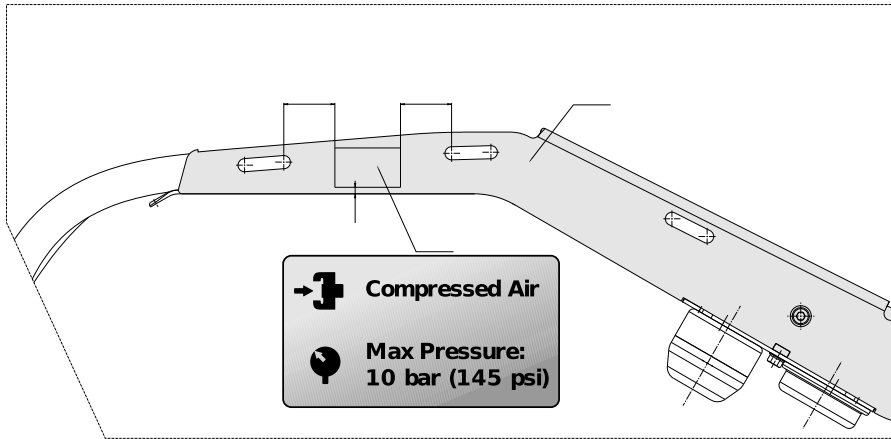

## Specifications

### AIR PRESSURE

Sticker on swivel arm of factory equipped DXRs:



This sticker is included in each cooling-/heat kit and should be mounted as illustrated.

### HYDRAULIC FLUID

For increased safety and machine efficiency, use a hydraulic fluid that is specially developed for fire hazardous environments, such as Quintolubric® 888 (fire-resistant hydraulic fluid from Quaker Chemical).

#### N.B. Replacing the hydraulic fluid

It is important to thoroughly perform each step of flushing the system by following the recommended procedure as described in workshop manual, chapter; "Complete change of hydraulic fluid".

### GENERAL INFORMATION

For more specifications, refer to owners manual of the machine.

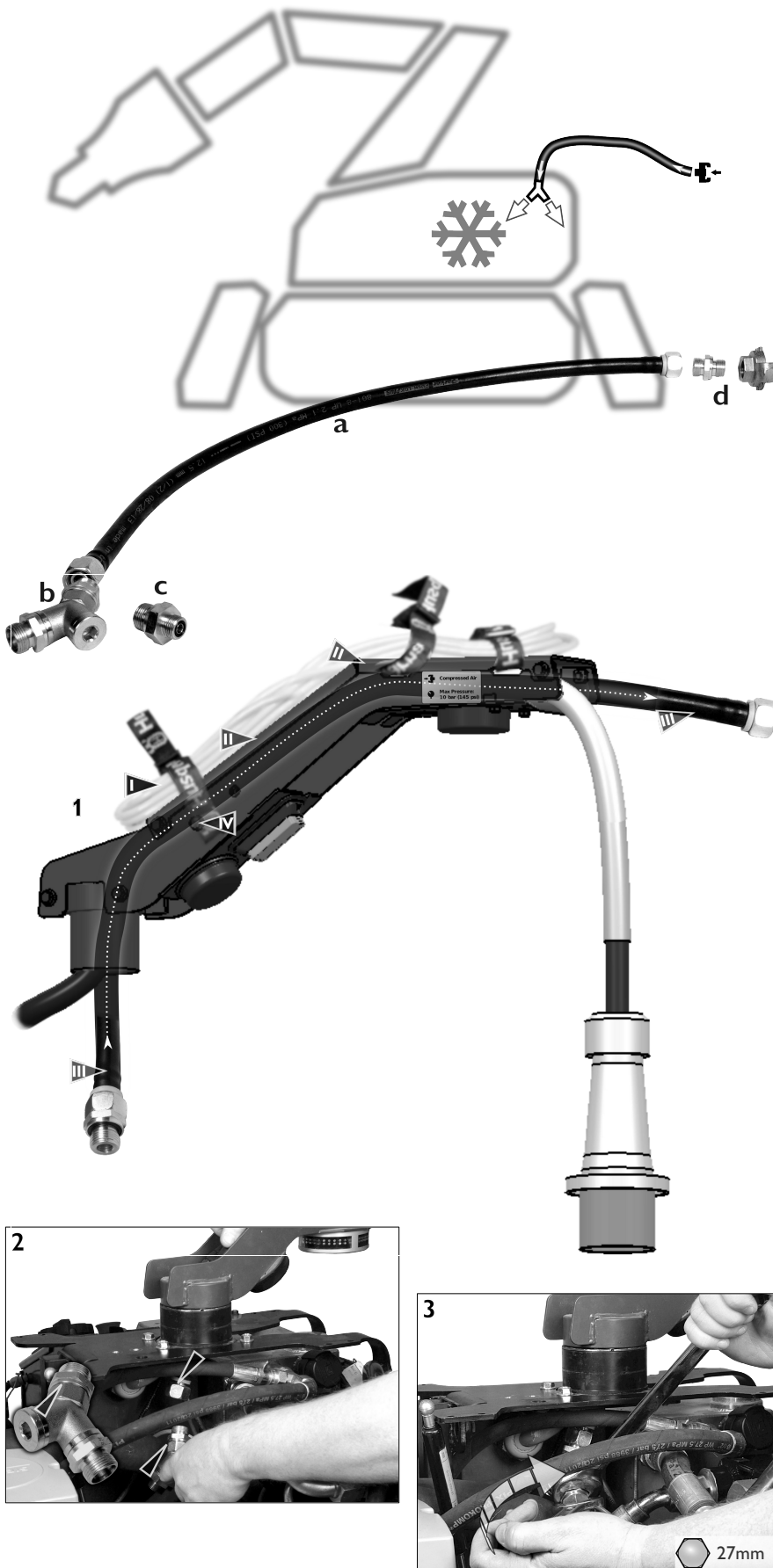

### Part of kit I and II

This chapter refers to mounting of parts that are included in both kit I and II (see chapter 2: 1a). One exit of the Y-split should be plugged if only one function is desired.

### Mounting of air supply hose and Y-split connector

#### PREPARATIONS:

- Remove left hand side bonnet (hood).
- Remove horn attached to frame of swivel arm.

#### Parts

- (a) air hose
- (b) Y-split connector
- (c) adapter between hose(s) and Y-split unit  
*(one exit may be blocked if hose split function is not desired)*
- (d) replaceable couplings to fit equipment of external air supply

### Mounting

#### 1. Fit air hose through swivel arm

- Remove web straps and bundle of emergency remote control cable
  - Lift up arm cover plates to expose arm interior.
  - Guide air hose through swivel arm along and to the right hand side of the electric cable - in the designated groove.
    - air hose and electric cable should both pass above the bolt (IV)
- Reposition arm cover plates (II)
  - Reassemble remote control cable (I) and fit sticker to swivel arm as indicated in previous chapter

#### 2. Fit on Y-split connector

- the “Y” should be mounted upside down.

#### 3. Tighten couplings

- use two 27mm spanners



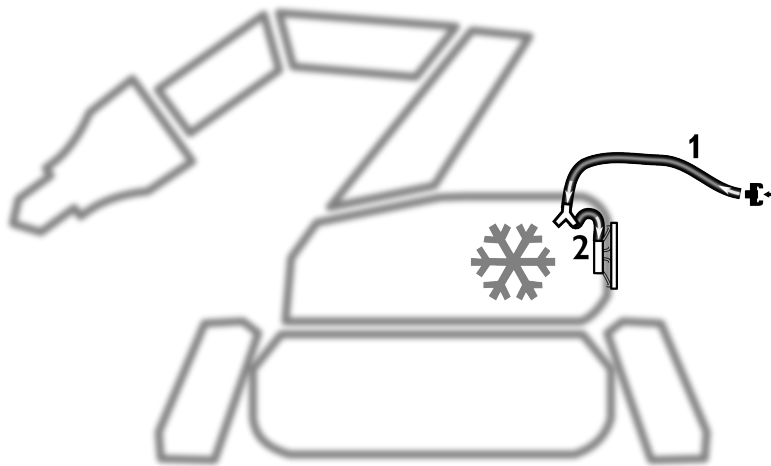

Full machine cooling kit comprising:

**1. FROM EXTERNAL AIR SUPPLY TO AIR HOSE Y-SPLIT**

See previous chapter.

**2. FROM Y-SPLIT TO MACHINE COOLER**

This kit allows for a cooled air flow over the machine cooler, to allow for more efficient cooling of the machine hydraulic liquid.

**AIR TO COOLER PARTS**

To fit the cool air supply kit to cooler, the following parts are needed:

- a: air hose with connectors from Y-split (a<sub>1</sub>, see previous chapter)
- b: air nozzle frame for grille mounting of counter-weight (or rear cover DXR270).  
one nozzle (b<sub>1</sub>) is attached to each corner (screwed through mounting hole into a hose coupler)  
four frame fasteners with compensating washers (or flange head fasteners DXR270)
- c: air distribution block.  
Positioned with two spacers (or bracket with two flange head fasteners DXR270)  
– attached with two flange hex head fasteners
- d: four nozzle hoses in two lengths to lead air from distribution block to each corner nozzle

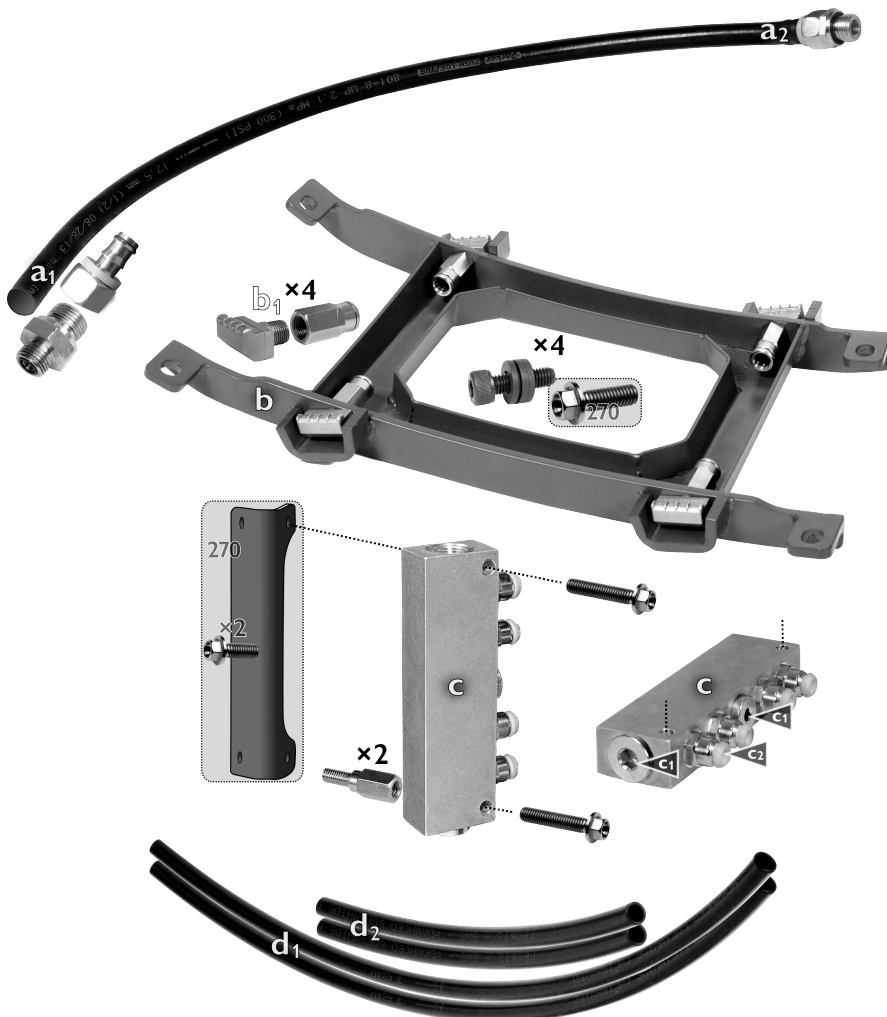

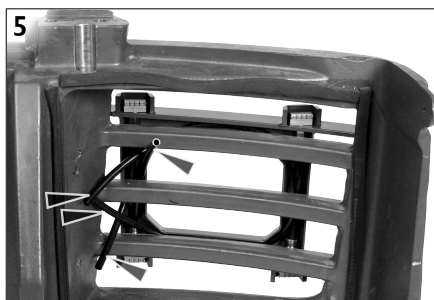
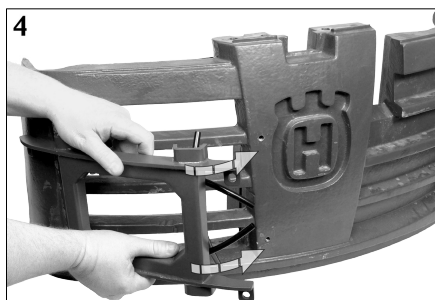
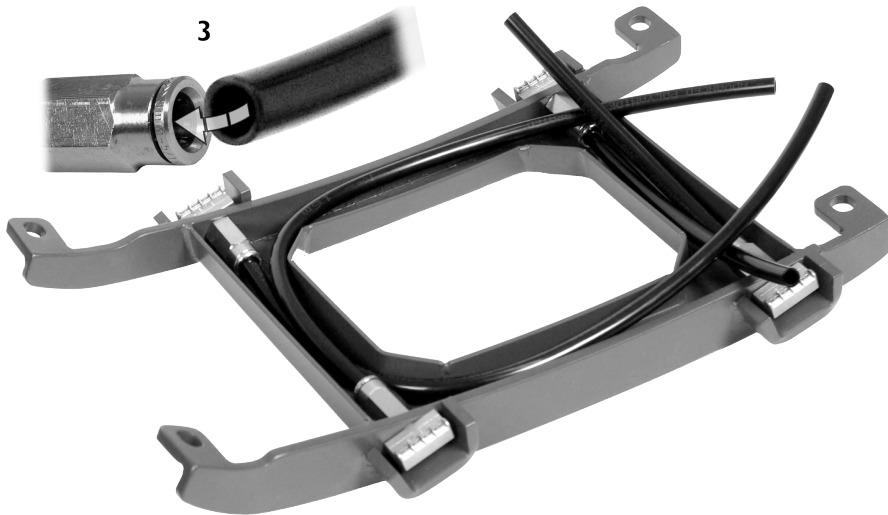
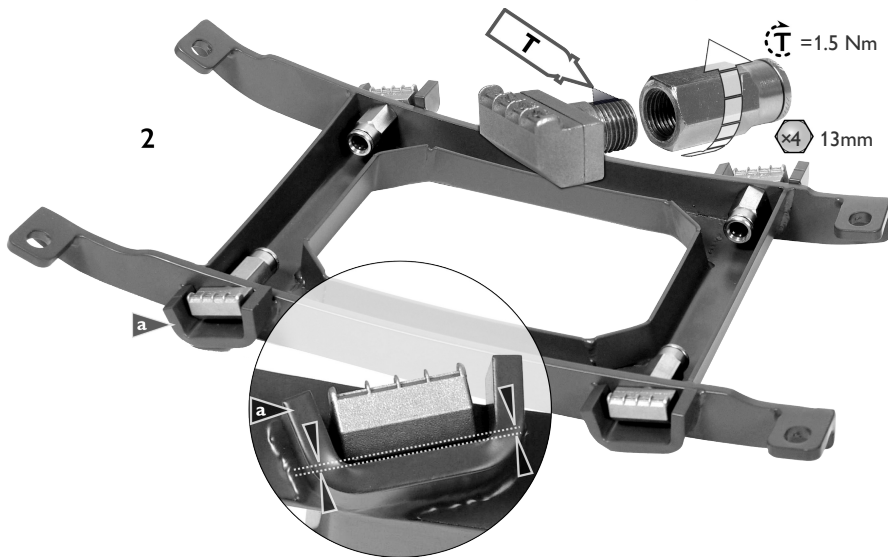
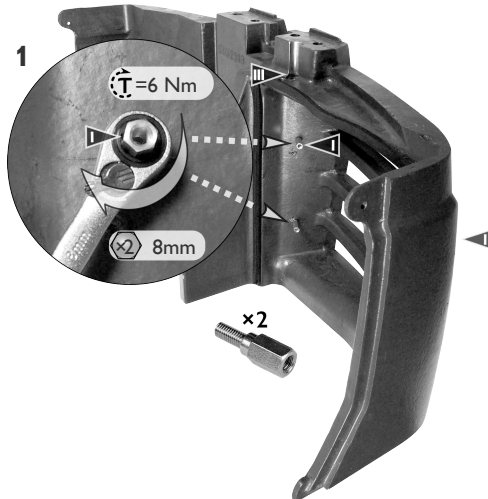
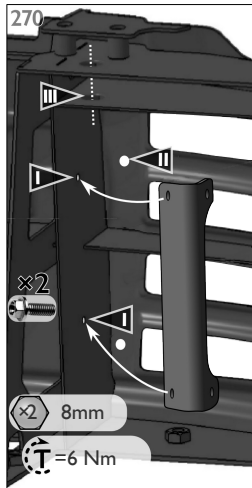

## Mounting

### PREPARATIONS:

- Remove left hand side bonnet (hood).
- Remove horn attached to cable swivel frame.
- Remove machine counter-weight (or rear cover. (see DXR WM chapter "Coverings"))
- Place machine counter-weight (or rear cover) on a sturdy bench.
- Check that your counter-weight/(rear cover) is prepared for this kit; I) with attachment holes for air distribution block on the interior side (step 1:  $\times 2$ ), II) air nozzle frame (step 4:  $\times 4$ ) on the exterior side and III) a drilled vertical hole for guiding the air hose:
  - if not; drill and thread holes according to hole patterns in Appendix: Cooling kit, machine, A) Counter-weight modification or B) Rear cover modification.

1. Fit spacers ( $\times 2$ ) to counter-weight (or bracket to rear cover<sup>270</sup>)
  - use an 8 mm spanner
2. Fit nozzles and hose couplings to frame
  - Apply Thread-locking compound:
    - T=medium strength pipe sealant for metal threads, e.g. Loctite 577
  - Do not over-tighten!
  - check that nozzles are properly mounted, well in line with nozzle head protectors (a)
3. Fit nozzle hoses to nozzle couplings
  - longer pair of hoses to left hand side of grille
  - shorter pair of hoses to right hand side of grille
    - press hose well into nozzle coupling for proper fit
    - place hoses inside of frame profile, as illustrated
4. Fit air nozzle frame to exterior side of grille
  - align frame mounting holes to threaded holes of counter-weight (back cover)
    - check nozzle hoses through grille as illustrated in step 5
5. Secure air nozzle frame
  - check nozzle hose passage through grille; two through each grille slot

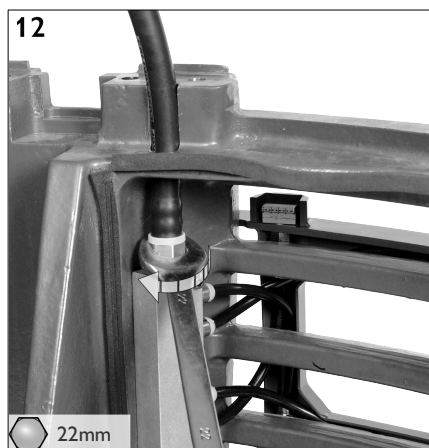
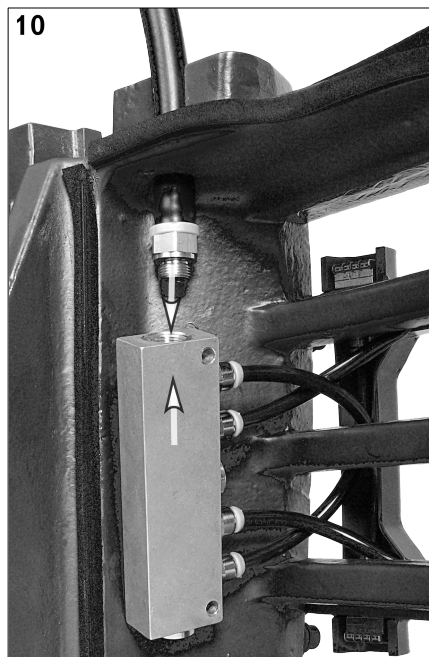
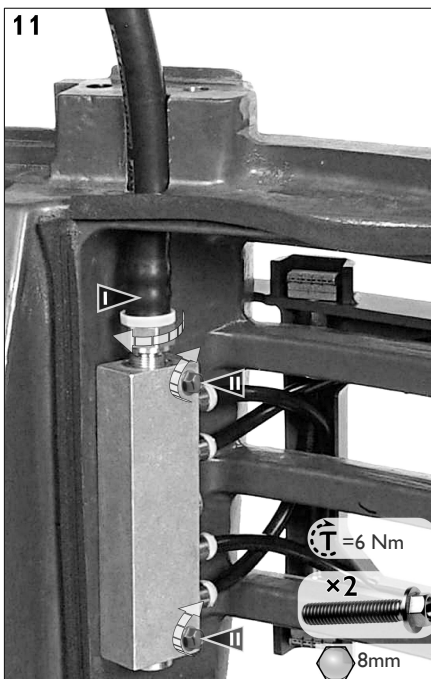
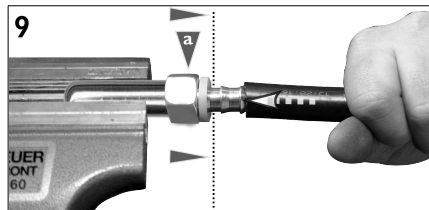
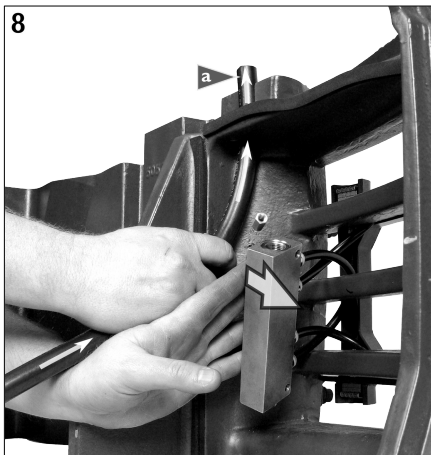
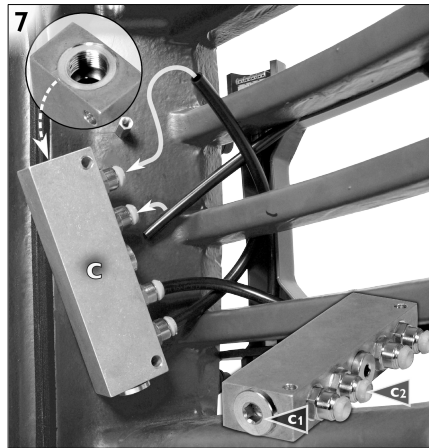
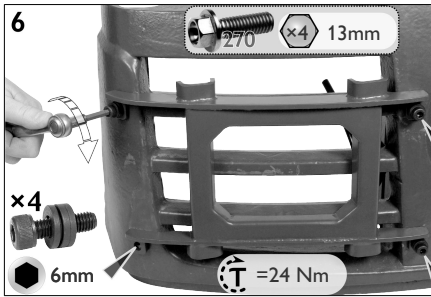

6. **Secure air nozzle frame**
  - insert fasteners with compensating washers (x4)
    - tighten with a 6mm Allen key
7. **Fit nozzle hoses into air distribution block couplings**
  - bottom plug *c1* and nozzle hose connectors *c2* should be mounted
  - keep air hose opening of distribution block upwards
  - fit nozzle hoses securely into each distribution block coupling, as illustrated
8. **Thread air hose through counter-weight (or back cover)**
  - thread a bare hose end (*a*) through hole, as illustrated
    - move distribution block gently aside for more space
9. **Mount coupling to bare hose end (*a*)**
  - fit end coupling over a fixed cylindrical shape as a means to apply good pressure by hand to force the hose on to the hose coupling.
10. **Join hose coupling and adapter with distribution block**
11. **Join in hose coupling with adapter with distribution block**
  - I. secure hose to distribution block end by hand
  - II. fit in distribution block fasteners (x2)
    - tighten with a 8mm socket wrench
12. **Tighten air supply hose coupling to distribution block**
  - tighten with a 22mm spanner

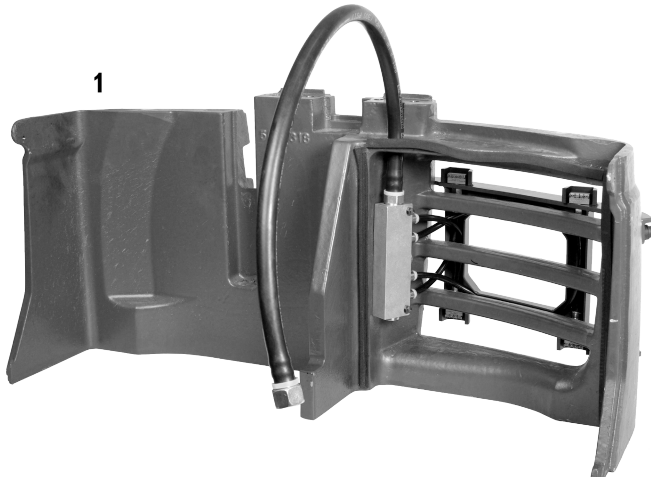

### Mounting cooler kit to air supply

#### 1. Mount prepared counter-weight (back cover)

- Mount by reversing dismantling instructions from WM manual.

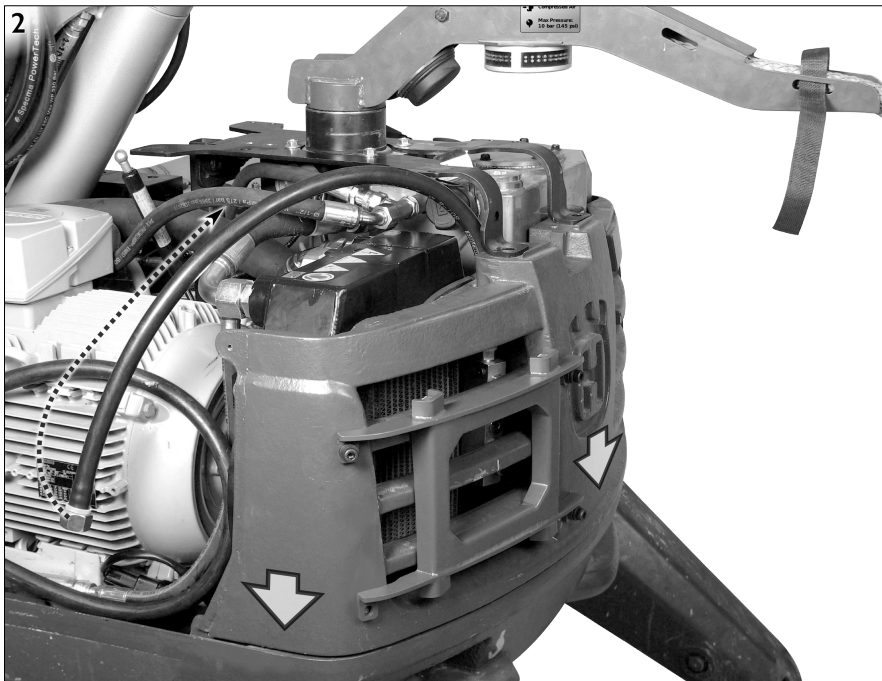

#### 2. Join air hose end with Y-split coupling

- arrange hose in a smooth bow to reach the Y-split coupling



#### 3. Fit air hose to Y-split connector

- screw on hose coupling by hand

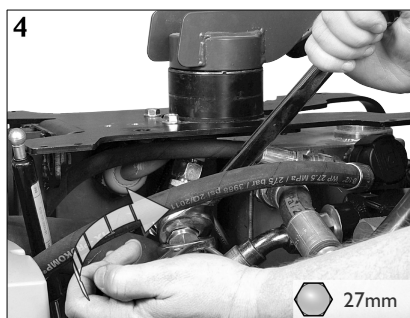

#### 4. Tighten hose coupling to Y-split connector

- use two 27mm spanners

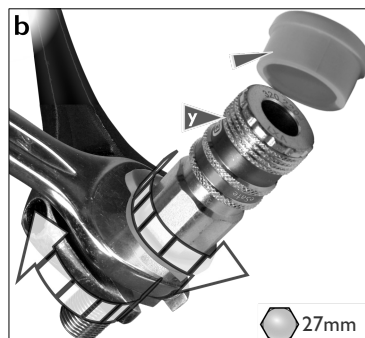
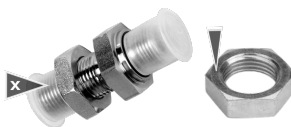
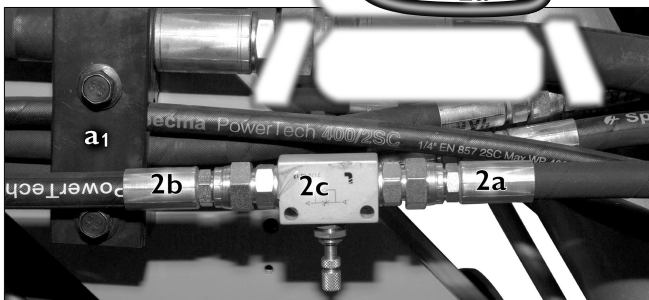
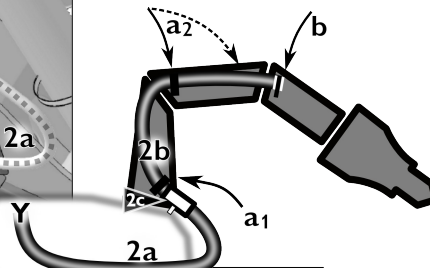
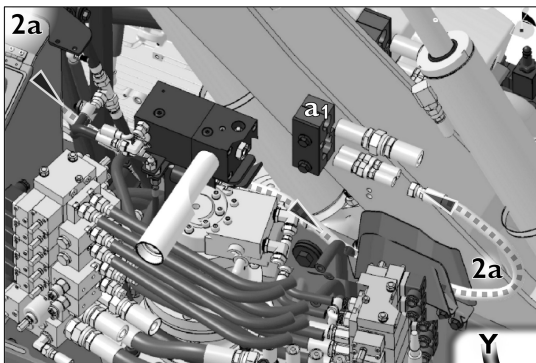

**Heat protective machine kit comprising:**

- Hose from external air supply to Y-split (see chapter 3)
- Air hose to boom bulkhead
- Heat resistant stick cylinder hoses
- Heat resistant ground contact surfaces

**PREPARATIONS:**

- If kit I is not already mounted:
- Fit hose from external air supply to Y-split as described in chapter 3.

**Air hose to boom bulkhead**

*The air hoses have a perforated skin to eliminate risk of exploding due to interior leakage.*

**PARTS**

- 2a: Air hose to length from Y-split to air flow tuner (2c).
- 2b: Air hose to length from air flow tuner (2c) to hose coupling of stick bulkhead.

	DXR270+275	Other models
2a	equal length	shorter
2b		longer

- 2c: Air flow tuner with adapters connecting air hoses 2a and 2b.

**FITTING OF AIR HOSES**

**2a - from Y-split through turret**

- thread air hose in from right hand side of boom base and backwards
- guide along lowest positioned hydraulic hoses
- guide air hose upwards to join Y-split connector, forming a smooth bow

**2c - fit air flow tuner**

- fit in hose coupling adapters with seal washers
- fit air hose 2a to entrance of tuner connector (check flow label)

**2b - from air tuner (2c) to stick bulkhead:**

- attach air hose 2b to exit of tuner connector
- attach air hose 2b to hose bracket a1 (in illustrated position), following the principles as described in step 1-2 below.
- attach air hose to remaining boom bracket(s) a2
- fit adapter (x) and quick coupling (y, with dust cap) to bulkhead (b)
- attach air hose 2b to stick bulkhead and its quick coupling (b)

*There is one more bracket for DXR 300/305 than for DXR 250, 270/275 and 310/15.*

## II. Heat protective kit, machine

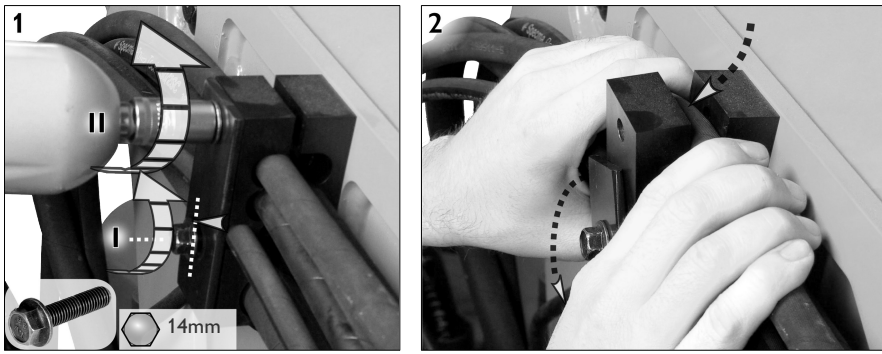

### AIR HOSES IN HOSE BRACKETS

1. apply to each of the hose brackets to right hand side of boom:
  - I. remove fasteners near an available hose space of each hose bracket
    - use a 14mm socket wrench
  - II. loosen the other fastener
2. Fit hose in desired space:
  - swing cover plate using other fastener as a hinge to open bracket
  - copy slack configuration of existing hydraulic hoses.

### Heat resistant stick cylinder hoses

#### PARTS

- 2d×2: Hydraulic hoses with silicone heat protective cover to replace existing stick cylinder hoses.

#### Mounting

Replace existing cylinder hoses following directions from WM of the DXR machine.

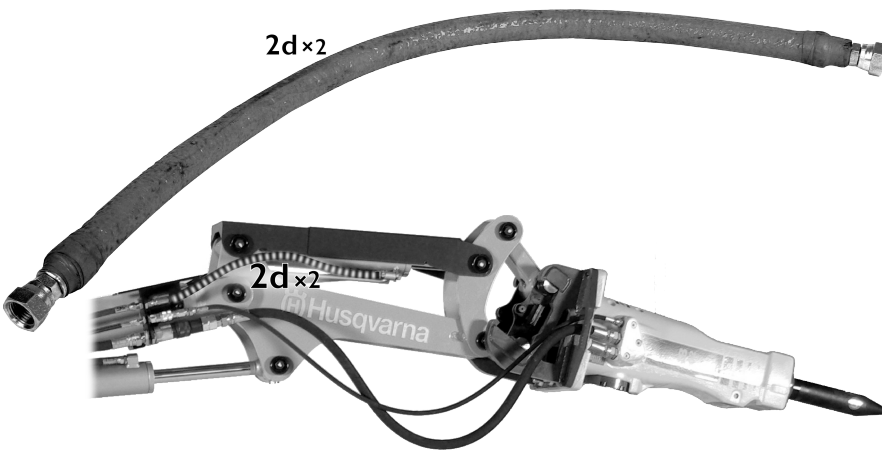

### Heat resistant ground contact surfaces

#### PARTS

- 2e×2: Steel tracks to replace existing rubber tracks.
- 2f×4: Steel pads to replace existing rubber pads of each outrigger.

#### Mounting of steel tracks

Replace existing rubber tracks following directions from WM of the DXR machine and "Accessory mounting - Steel tracks".

#### Mounting of steel pads

Replace existing rubber pads following directions from WM of the DXR machine.

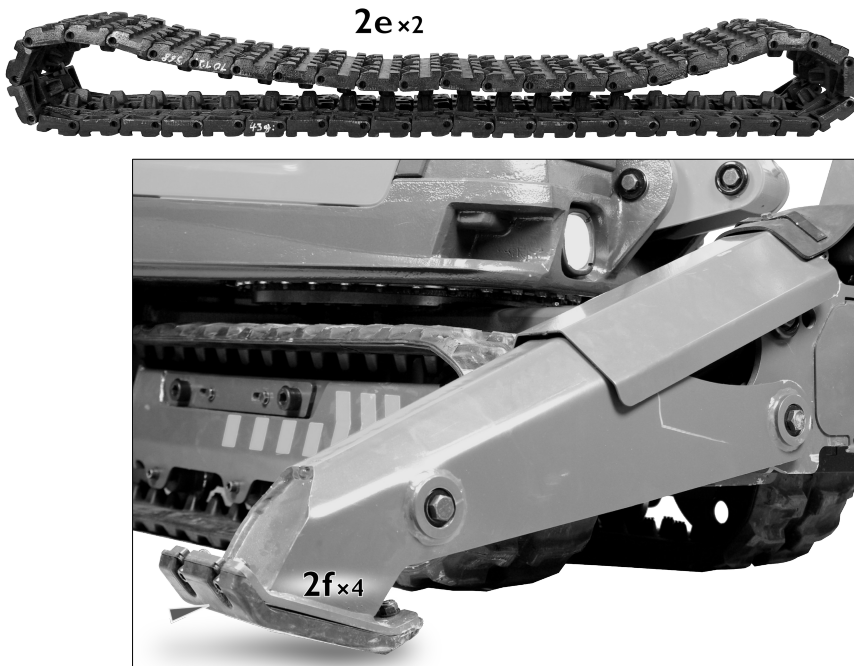

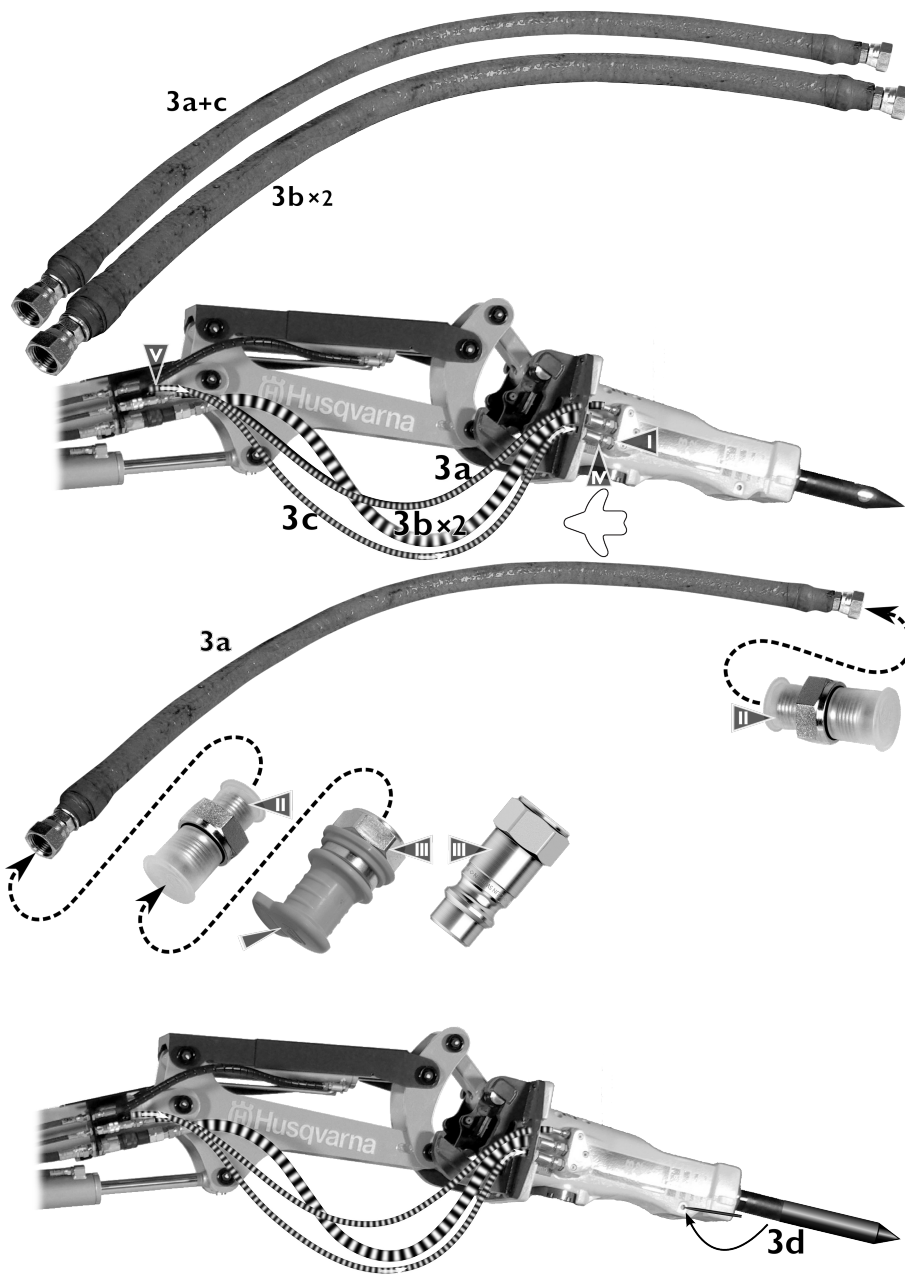

This heat protective kit comprises:

- Heat resistant hoses to hammer
- Heat protective extra long chisel tool

#### Heat resistant hoses to hammer

This bundle of heat resistant silicone covered hoses should replace existing grease and hydraulic hoses and add an air hose to the hammer.

#### PARTS

- 3a+c:** Air hose and grease hose (thinner dimension), from bulkhead to hammer.
- 3b x2:** Hydraulic hoses (thicker dimension) from bulkhead to hammer (on either side).

#### FITTING OF HOSES

- Simply replace existing hydraulic hoses (3b), one by one.
  - If necessary, refer to hose couplings section of DXR machine Workshop Manual.
- When adding kit air hose, perform the following measures:
  - I. remove Allen plug of the Atlas hammer
  - II. mount kit adapters to hose
  - III. fit on hose male quick coupling (with dust cap)
  - IV. fit hose adapter to hammer
  - V. fit quick coupling to bulkhead air inlet

#### Heat protective extra long chisel tool

The extended chisel length allows for increasing distance between hammer and the source of heat radiation.

#### PARTS

- 3d:** Replace existing chisel of the hammer (SB202 or SB302).
- Also replace the existing lock pin with the new one from kit bundle.

#### FITTING OF NEW CHISEL TOOL

- Simply replace existing chisel.
  - If necessary, refer to the Tool Manual.



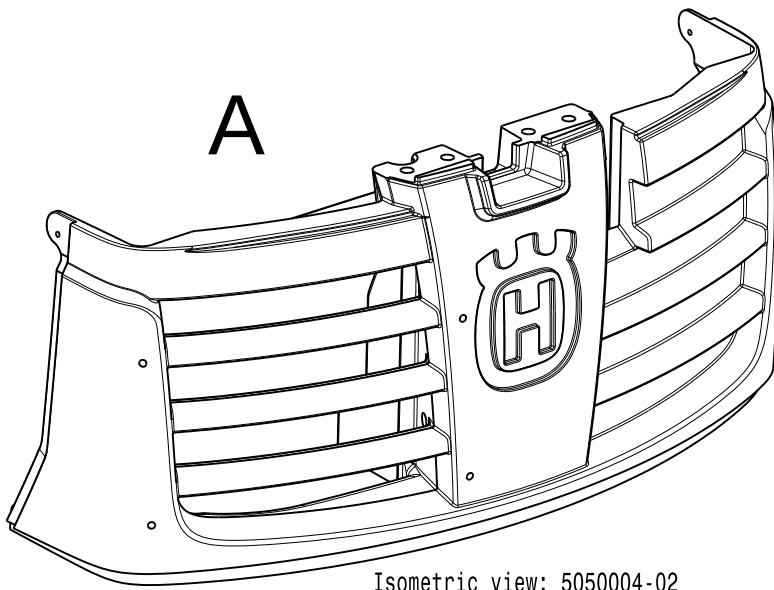

**UPGRADING OLDER MACHINE**

This appendix is for machines lacking factory made preparations for current range of cooling accessories as described in chapter 4.

A complete set of drawings are available from Husqvarna support site.

**A: Counter-weight modifications**

Remove counter-weight and follow the illustrated preparations (A) needed for cooling accessory mounting.

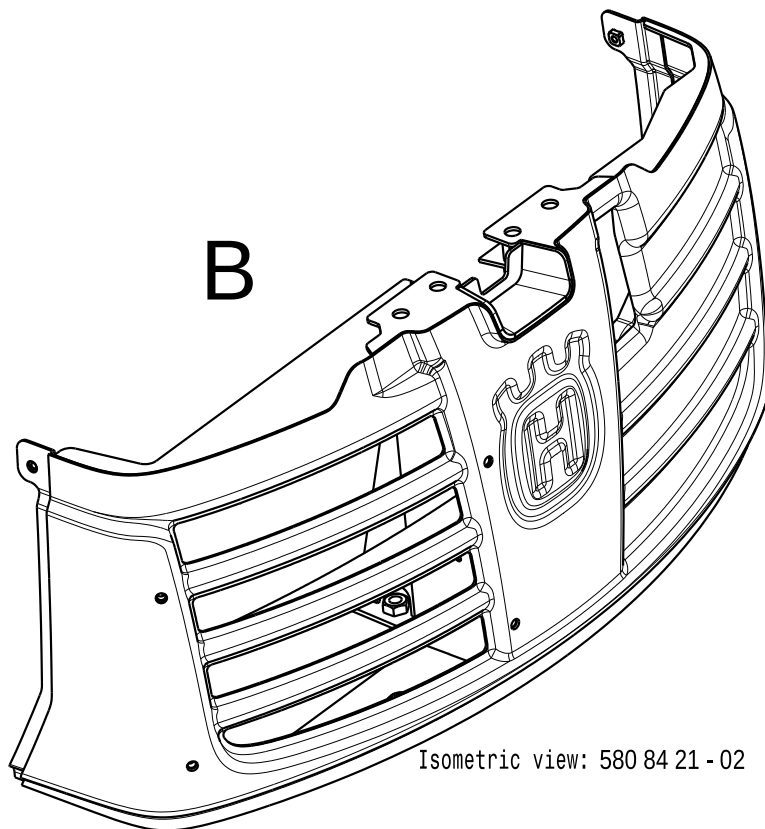

**B: Rear cover modifications**

Remove rear cover as described in chapter 4 and follow the illustrated preparations (B) needed for cooling accessory mounting.

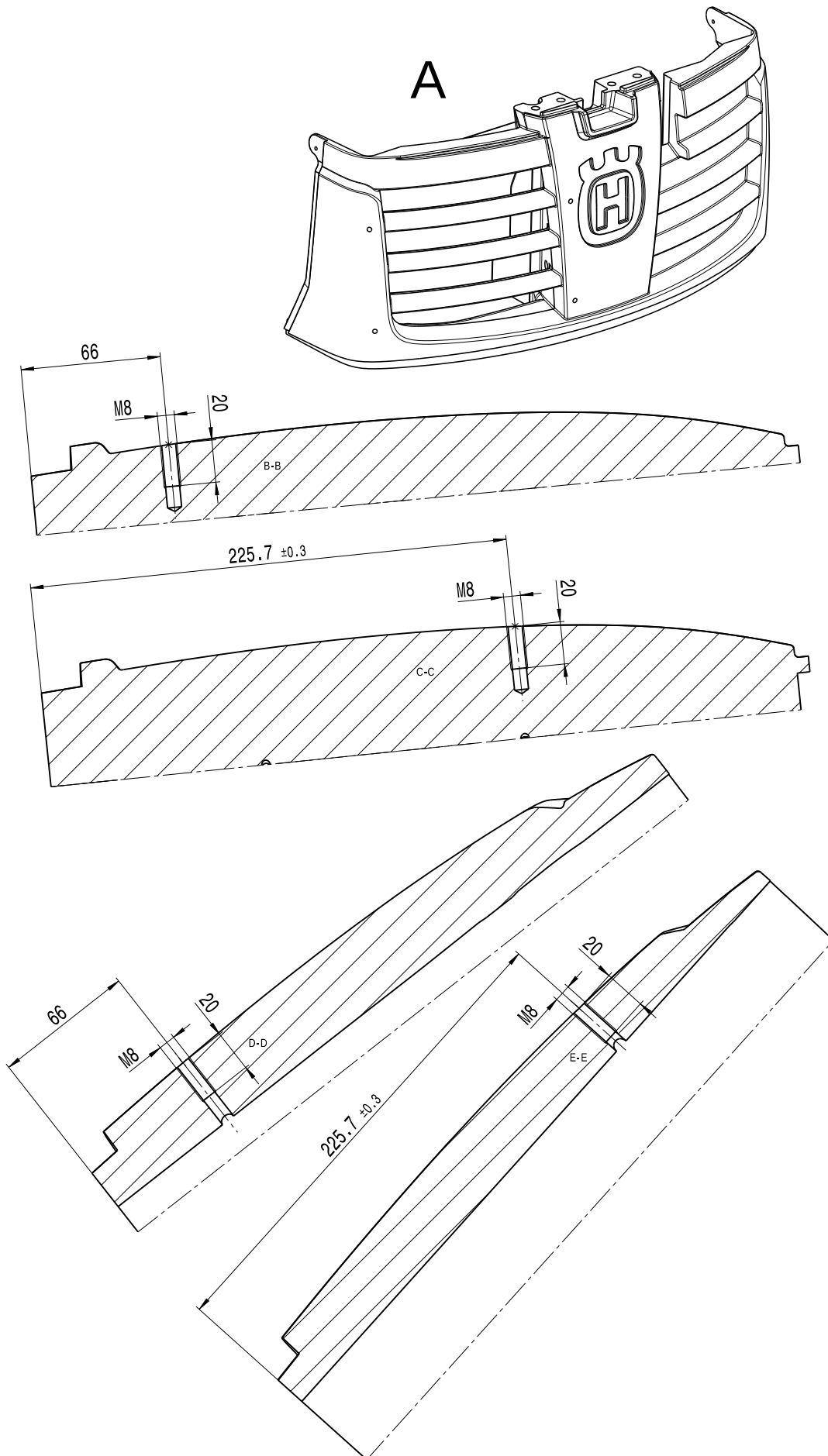

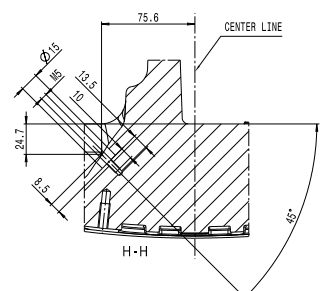
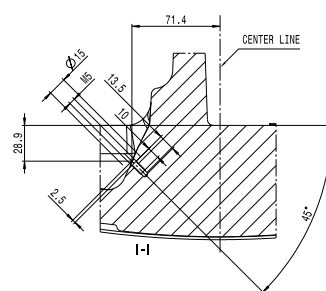
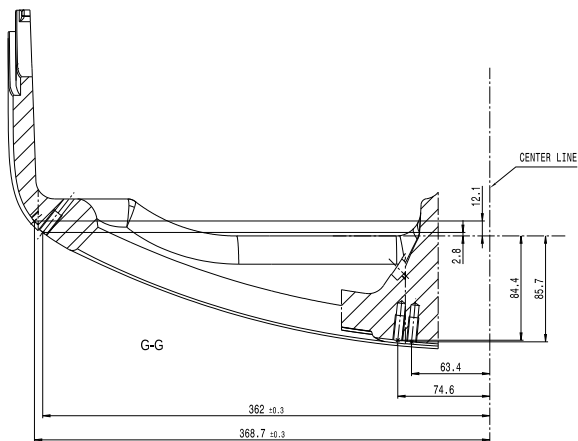
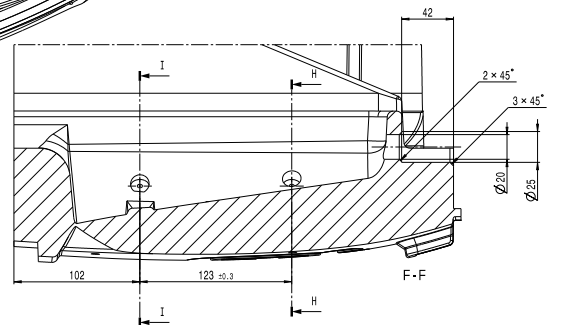
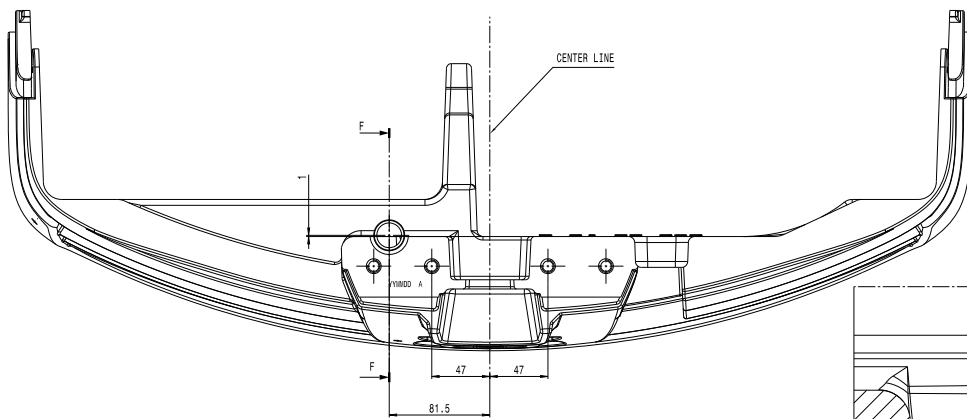
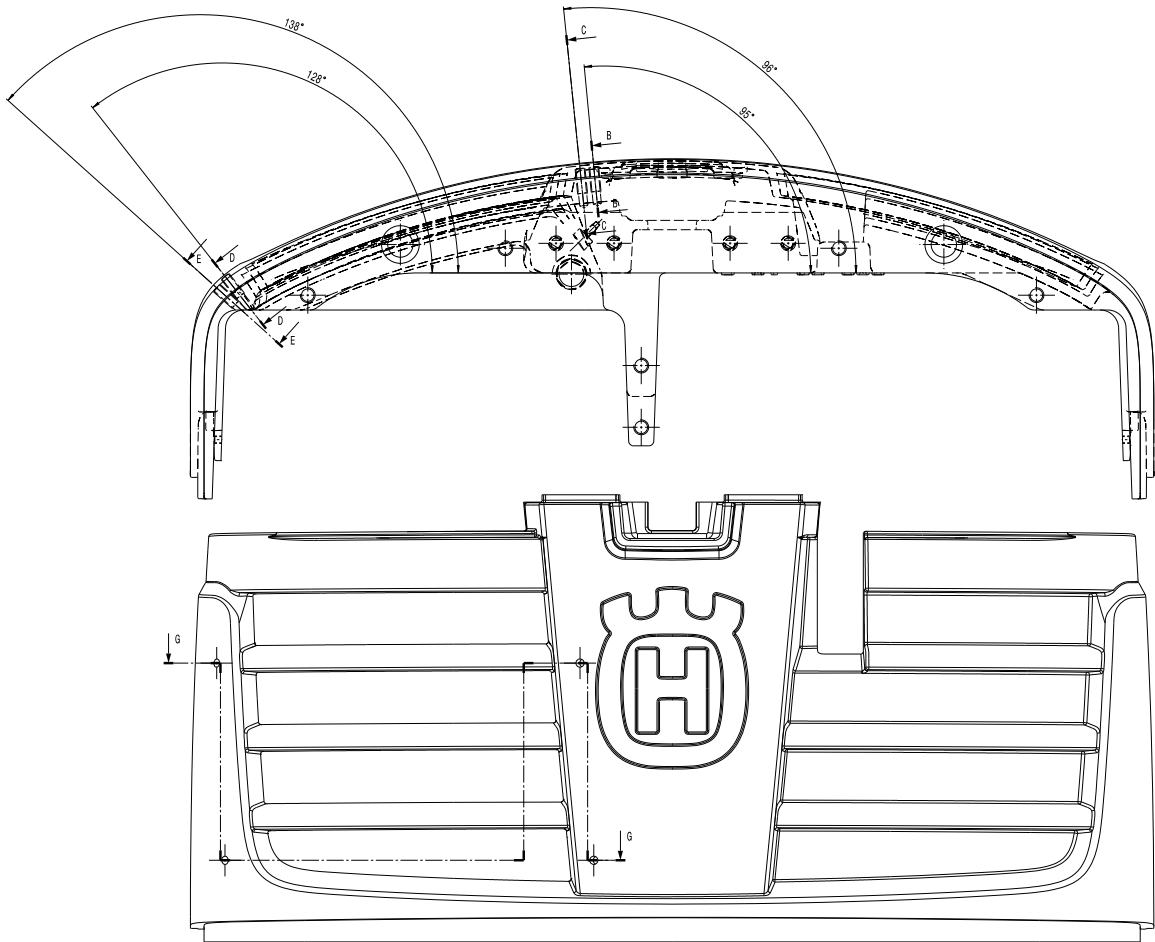

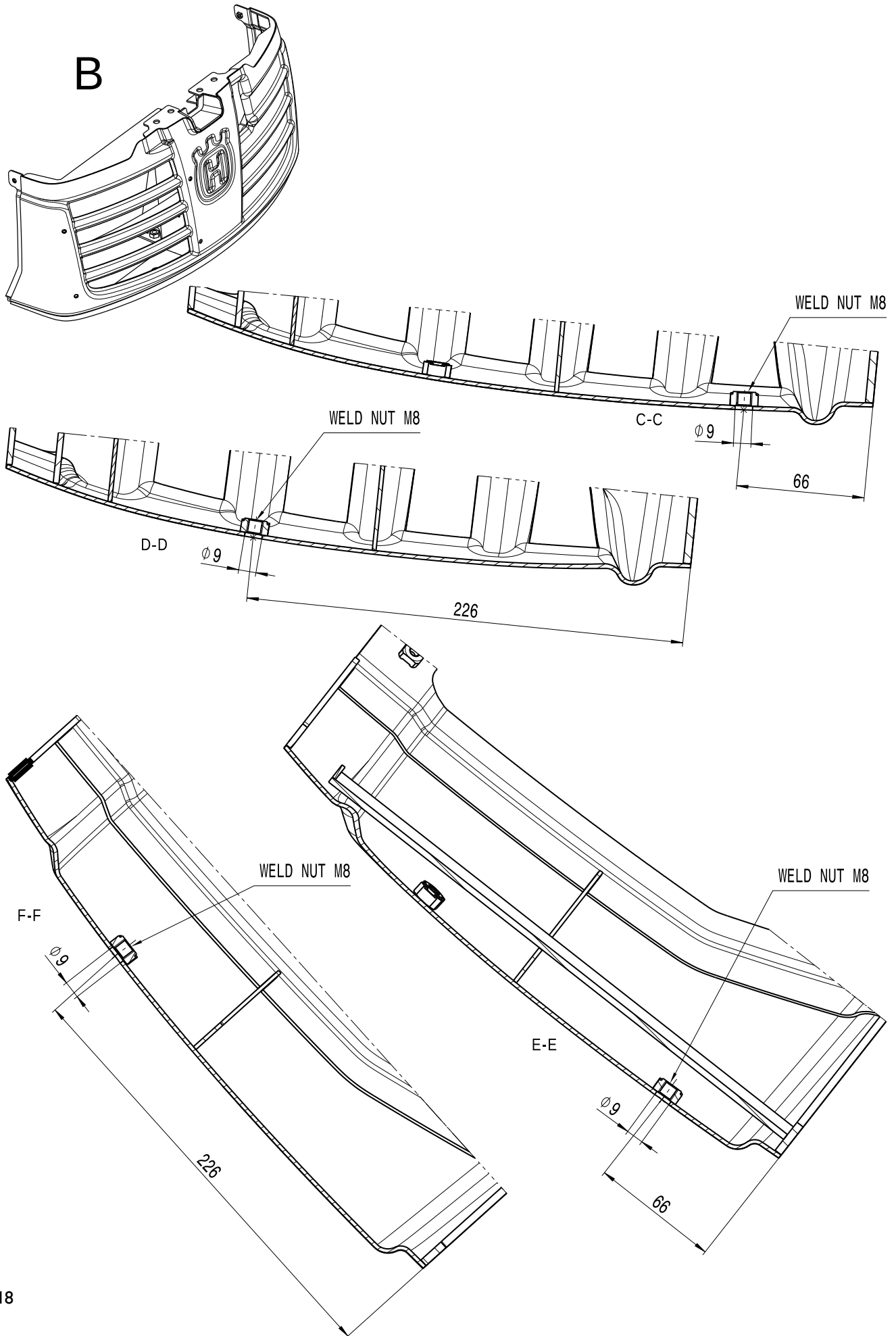

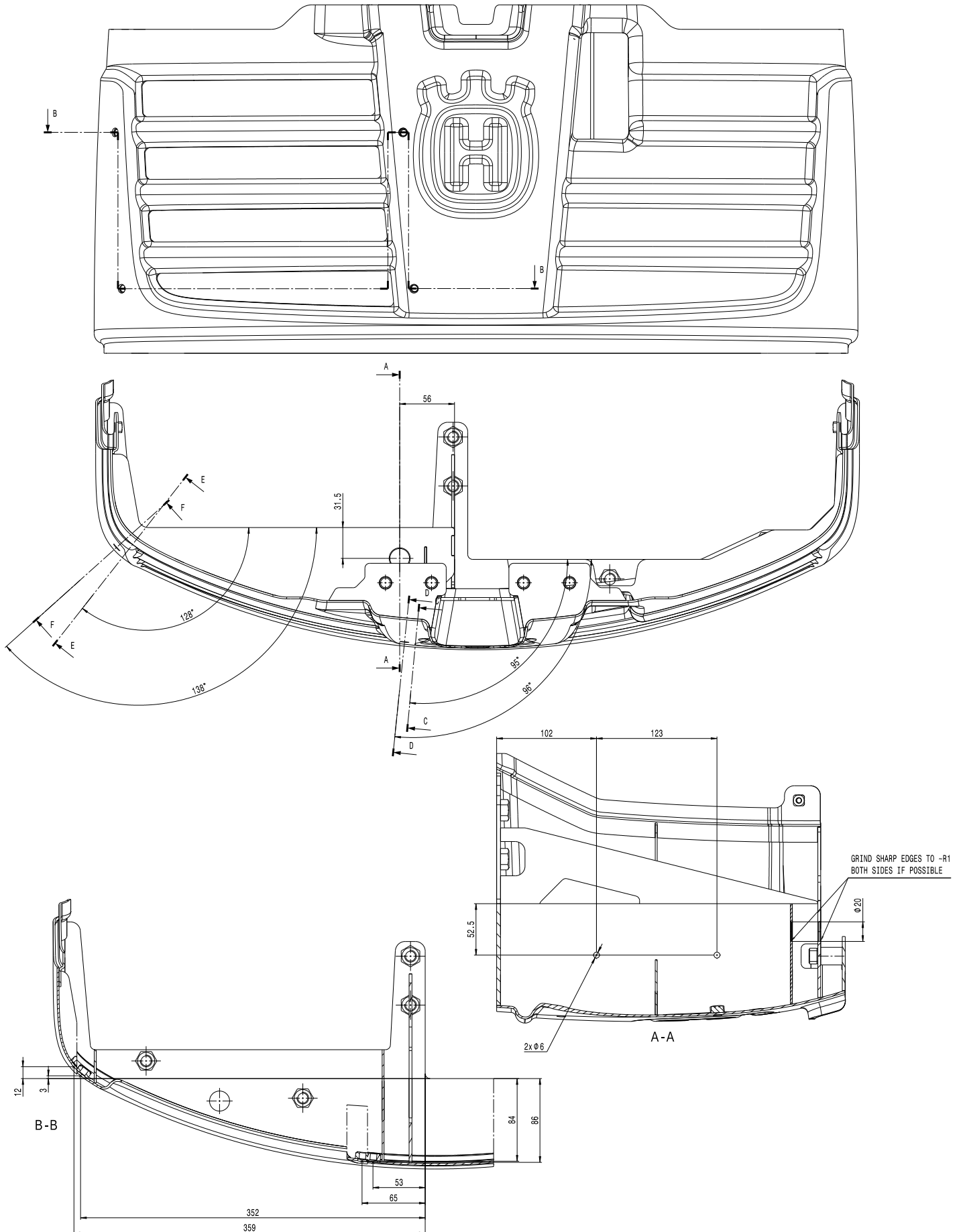



[www.husqvarnacp.com](http://www.husqvarnacp.com)

English